



Item # _____

RSB Salamander Broiler



STANDARD FEATURES:

- ◆ All stainless steel front and sides.
- ◆ Individually adjustable infra-red burners rated at 17,500 BTU/hr. each.
- ◆ Spring balanced broiler grid moves up and down with positive locking three positions
- ◆ Standing pilots for instant ignition.
- ◆ Easy loading and unloading with a roll-out carriage.
- ◆ Full width removable crumb pan for easy cleaning.
- ◆ Mounts with heavy duty wall brackets.

RSB-36 Shown

OPTIONS:

- ◆ Range mounting kits to mount onto high shelf of any size range
Note: Width of the unit cannot exceed the width of range to which it is to be attached.

Royal Salamander Broiler offers versatility, high performance, and heavy duty features designed to last.

36 inch (RSB-36) is equipped with two gas valves to separately regulate each burner. Efficient Infra-red burners provide uniform heating. The spring loaded broiler surface makes for easy adjustment into three secure height positions.

For easy loading and unloading, the carriage assembly rolls out a full nine inches.

All stainless steel front and sides with a full width removable broiler pan make clean up easy.



RSB Salamander Specifications

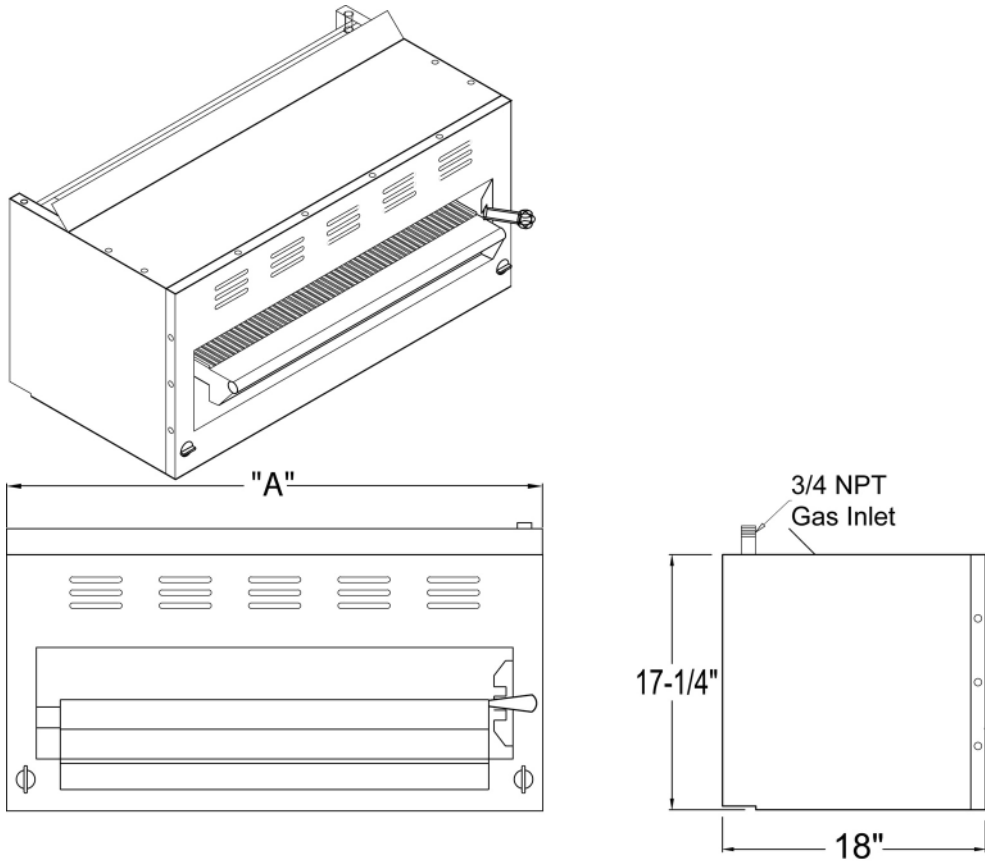

MODEL NO.	WIDTH (A)	DEPTH	NUMBER * OF BURNERS	TOTAL BTU's.	SHIP WEIGHT
RSB-24	24"	18"	1	17,500	175 Lbs.
RSB-36	36"	18"	2	35,000	210 Lbs.
* Note: Infra-red burners rated @ 17,500 BTU/hr. each					

Gas Connection: 3/4" NPT on the right hand rear at the top of the appliance
The pressure regulator (supplied) is to be connected here by the installer.

Gas pressure: 5" W.C. - Natural Gas
10" W.C. - Propane

Combustible Clearances:
4 inches sides
4 inches rear

Non-combustible Clearances:
0 inches sides
0 inches rear

Specify type of gas and altitude,
if over 2,000 feet, when ordering.

Due to continuing product development to ensure best possible performance, these specifications are subject to change without prior notification

3245 CORRIDOR DR. MIRA LOMA, CA. 91752 951.360.1600 FAX 951.360.7500 (03/07)