

**MIXERS**

“Superior *quality* product  
at an *affordable* price !”



**SM200**



**SM300**



**SM402NA**



**SM100CL**



**SM100HV**

Planetary mixers

**Standard Features**

- Units with a serial number starting with **S** are conform to the following standards:
  - CSA C22.2 No 195
  - UL std. 763
  - EN 454-00 section 6.1
  - EN 954-1 article 6.2.2
  - EN 1088-95, articles 4.2.1, 5 and 6
  - CSA Z432-04 articles 5.5.2.2, 5.6.1, 6.2.3.2, 7.17, 10.2 and 10.3
  - RSST rules 172 to 175, 184, 187, 189, 190 and 192
- 1 stainless steel bowl.
- Mixing hook, whip and flat beater.
- Manual bowl lift.
- Standard #12 attachment hub.
- See through bowl guard with safety interlock. Prevents operation when guard is open.
- From 1/2 HP up to 1 1/2 HP motor, lubricated ball bearings, air cooled with thermal overload protection that automatically shuts the mixer off in an overload situation.
- High torque transmission. Grease lubricated, antifriction ball bearings. Heat treated steel alloy gears.
- Integrated ingredient chute.
- Cord and plug: 6 feet flexible wire cord.
- Large, easy to reach controls with separate start and emergency stop.
- 3 speeds: low, intermediate and high (see chart on back).
- Cast iron frame with long lasting lead free enamel coating for quick cleaning.
- ETL and NSF listed
- One year parts and labor limited warranty

**OPTIONAL**

- 1 extra stainless steel bowl.
- SM100HV: Meat grinder attachment.
- SM100CL: Vegetable and pepperoni slicer with 3 cheese shredders attachment.

SM Series mixers

For over 20 years, Doyon’s SM series planetary mixers have been the most competitive mixers on the market. From 20, 30 and 40 quarts, Doyon offers the most flexible, dependable heavy duty mixers of the industry at a price that can’t be beat !

### SM200

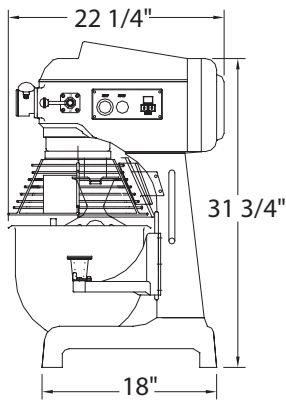
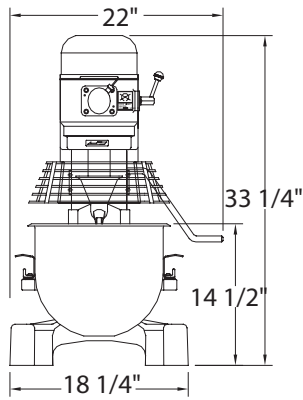

### SM300

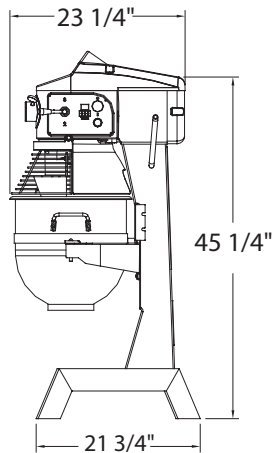
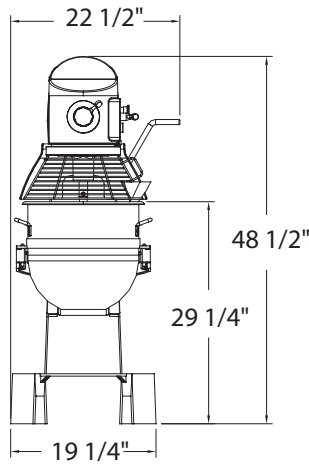

### SM402NA

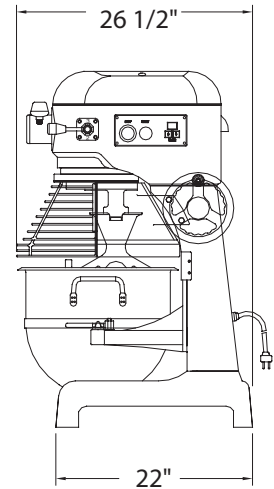
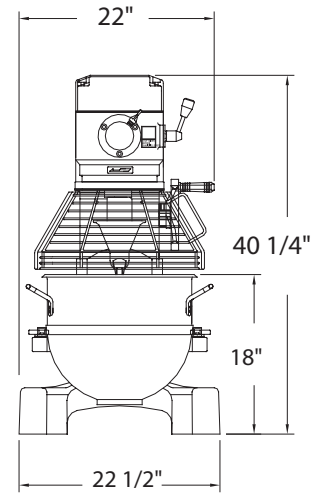

MODEL	CAPACITY	CRATED WEIGHT	OVERALL EXTERIOR DIMENSIONS			HUB	DOUGH CAPACITY (50% AR)		MOTOR	SPEEDS (RPM)			VOLTS	A	NEMA
			W	D	H		lb	kg		1st	2nd	3rd			
SM200	20	250 lb 114 kg	22" 559 mm	22 1/4" 565 mm	33 1/4" 845 mm	Yes	10	4.5	1/2 HP	107	198	361	120	12	5-15P
SM300	30	525 lb 236 kg	22 1/2" 572 mm	23 1/4" 591 mm	48 1/2" 1232 mm	Yes	15	6.8	1 HP	95	176	321	120	16	5-20P
SM402NA	40	575 lb 261 kg	22" 559 mm	26 1/2" 673 mm	40 1/4" 1022 mm	Yes	30	13.6	1 1/2 HP	90	170	310	208-240	14	6-20P
SM100CL	-	60 lb 27 kg	Other voltages available Specifications and design subject to change without notice.												
SM100HV	-	20 lb 9 kg													



Your local distributor:

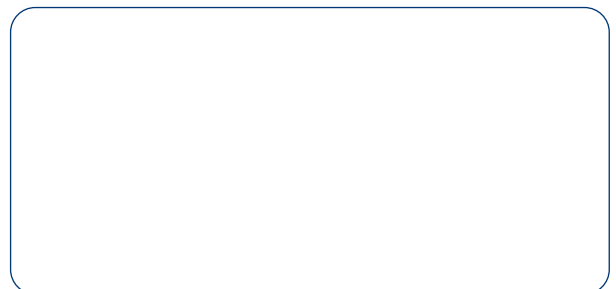

1255, rue Principale  
Linière, Beauce, Québec, Canada G0M 1J0

Telephone : (418) 685-3431      Fax: (418) 685-3948  
Canada : (800) 463-1636      U.S.: (800) 463-4273  
E-Mail : doyon@doyon.qc.ca      Internet: http://www.doyon.qc.ca